



FTS34/35 Thermo Air Velocity Transmitter



Application

〈 Feature 〉

- Linear adjustment function
- Switch for physical quantity : [m/s] 、 [ft/s] 、 [km/h] 、 [mph] 、 [knot]
- Option RS-485 Communication Interface, Modbus RTU protocol
- Configuration measuring range, analog output, station number by dip switch & RS-485
- Off SET function by bottom or RS-485
- Programmable software : DATA LOGGER, record, and chart analysis

〈 Application 〉

- Monitor gas and flow for industrial process
- HVAC, building, factory, Clean room, hospital
- Semiconductor, electronics, paper, environment, food, Pharmaceutical, biotechnology industry

Specification

Input

input type of air velocity	thermal mass flow sensor
air velocity measuring range	2 m/s ; 10 m/s ; 20 m/s ; 40 m/s
air velocity min. measuring range	0.2 m/s

Output

output	4 ... 20 mA / 0 ... 10 VDC
signal connection	3-wire
load resistance	current output : $\leq 500\Omega$; voltage output : $\geq 10K\Omega$
response time	reach 90% of ultimate value within 3 sec.
angular dependence	< 3% measuring value (when the angle < 10°)
display type	LCD Module with black light
display range	upon request, one deimal place
height of character	5.56 mm

Accuracy (+ 25°C)

accuracy	$\pm 2\%$ F.S. (nonlinear error, hysteresis error, repeatability error)
thermal sensitivity temp. error	0.1 % / °C

Environment

measured media & temperature	air ; 0 ... 50°C
working temperature	0 ... 50°C
environment humidity	95 %RH (non-cond.)
storage temperature	-20 ... + 60 °C

Electrical

power supply	8 ... 35VDC & 12 ... 30VAC
current consumption	DC 8V : 300mA , 24V : 100mA AC 12V : 350mA , 24V : 180mA
overvoltage protection	DC : < 45V ; AC : < 40V
electrical connection	terminal / M12 connector

Installation ; Protection

installation ; way to fix	duct / remote ; flange
protection degree	IP 54
electrical protection	⊙ polarity protection ⊙ over-voltage ⊙ short circuit

Certification

CE Certification	Emission EN 61326-1 : 2006 Class B EN 55011 : 2009 / A1 : 2010 Group 1 Class B
	Immunity EN 61326-1 : 2006 EN 61000-4-2:2009 EN61000-4-3:2006/A2:2010 EN 61000-4-8:2010

Material

housing / probe	PC fire-proof (UL94V-2) / PC fire-proof
measuring head / cable	PC with glass fiber
weight	FTS34 : 147g / FTS35 : 200g

Ordering Guide

type	FTS	35	—	40	1	1	—	1	5	M
installation	duct remote	34 35								
range	2 m/s 10 m/s 20 m/s 40 m/s		—	02 10 20 40						
output	4 ... 20 mA 0 ... 10 V RS-485				1 6 9					
power supply	8 ... 35 VDC & 12 ... 30 VAC					1				
analog / modbus	analogue RS-485 RS-485 & analogue ※ M type - M12 (5 P) metal connector or N type - M16 cable gland						— — —	0 1 2		
cable (for remote type)	2 m cable (FTS35) 5 m cable (FTS35) customize								2 5 W	
option	cable gland M12 (4P or 5P) connector (with 2 m electrical cable) display other request									N M D W

Electric Connector

unit : mm

【 M type (M12-4PIN metal connector) RS-485 or analogue

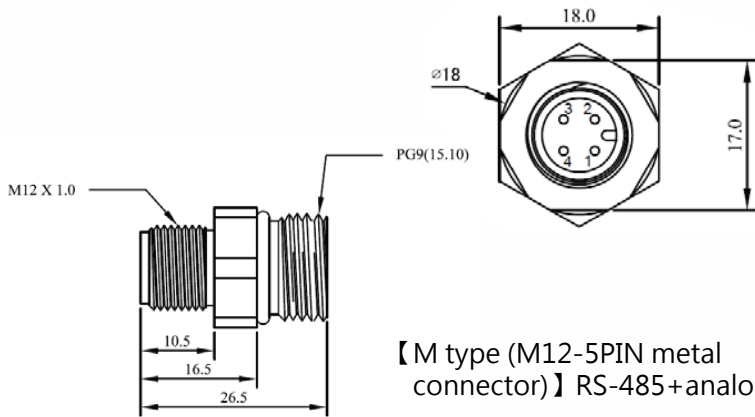

【 M type (M12-5PIN metal connector) RS-485+analogue

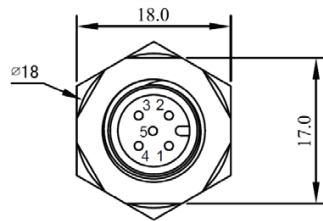

【 N type (M12 cable gland) RS-485 or analogue

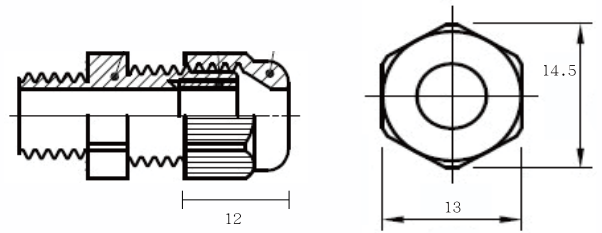

【 N type (M16 cable gland) RS-485+analogue

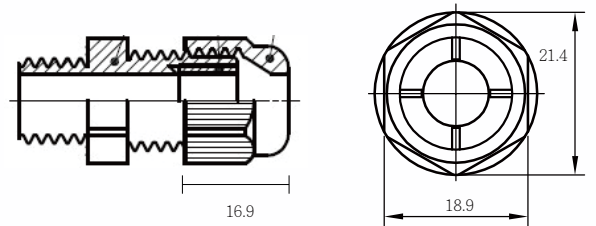

Dimension

【 FTS34 (duct) 】

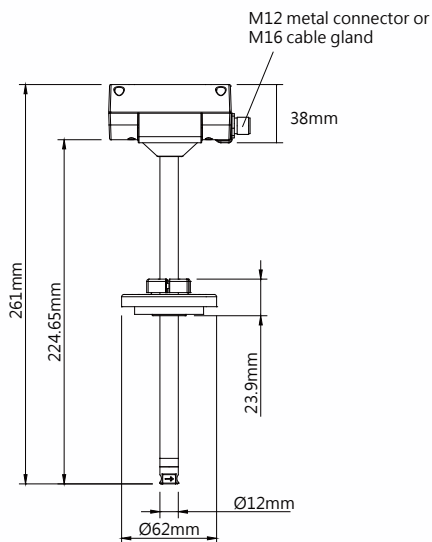

N type (M16) or M type (M12, 5P) : RS-485+analogue
M type (M12, 4P) : RS-485 or analogue

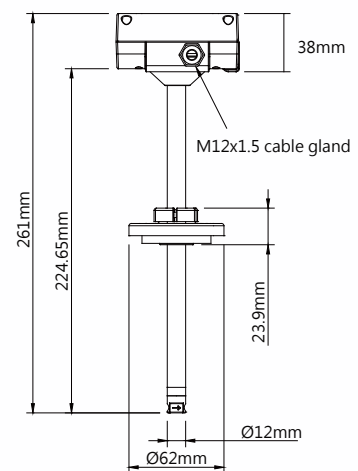

N type : RS-485 or analogue

Dimension

【 FTS35 (remote) 】

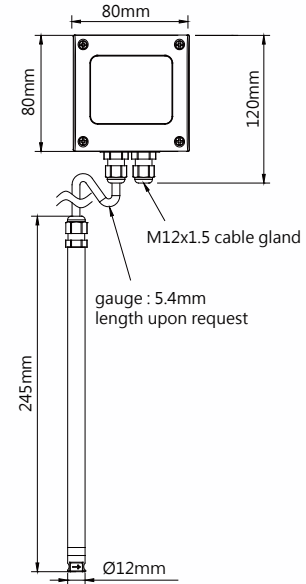
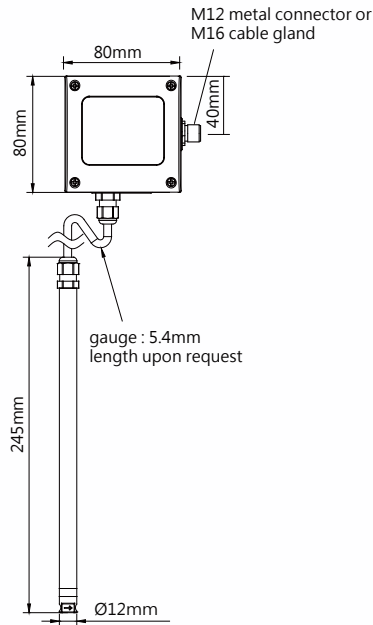

N type (M16) or M type (M12, 5P) : RS-485+analogue
M type (M12, 4P) : RS-485 or analogue

N type : RS-485 or analogue

Analogue Diagram

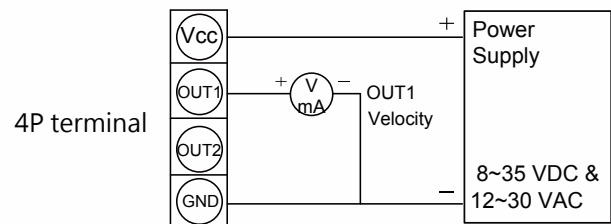
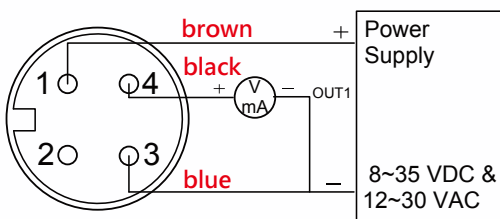

RS-485 Diagram

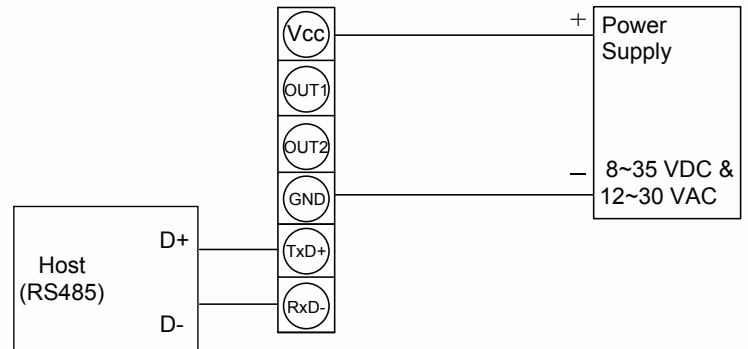
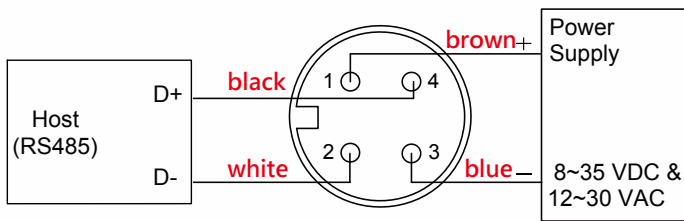

Analogue + RS-485 Diagram

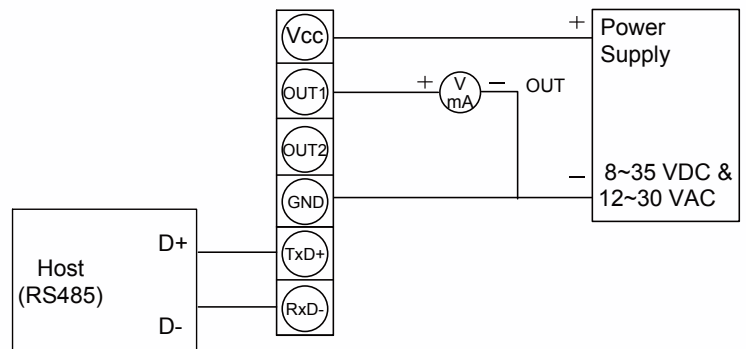
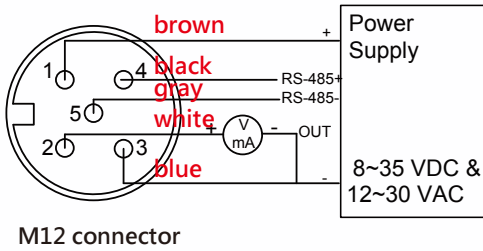

USB to Isolated RS485 Application

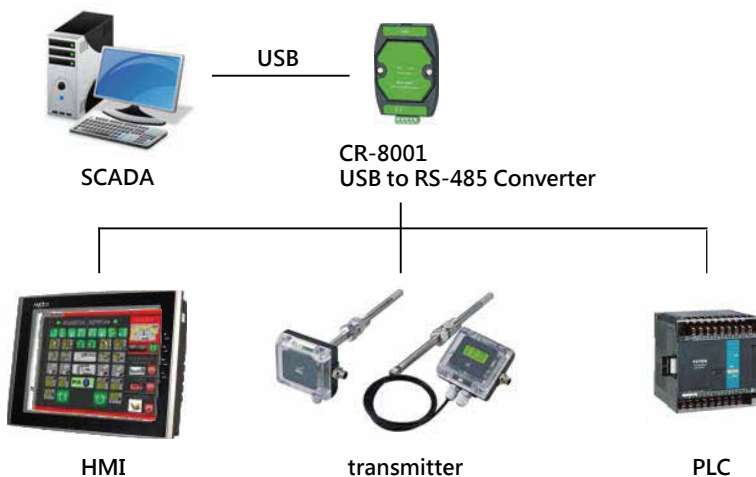

※ Device

1. PC
2. RS-485 to USB Converter
3. power supply
4. UI software

※ option converter: CR-8001

※ EYC free programmable software
<http://www.eyc-tech.com/download/download149.html>

DIP Switch

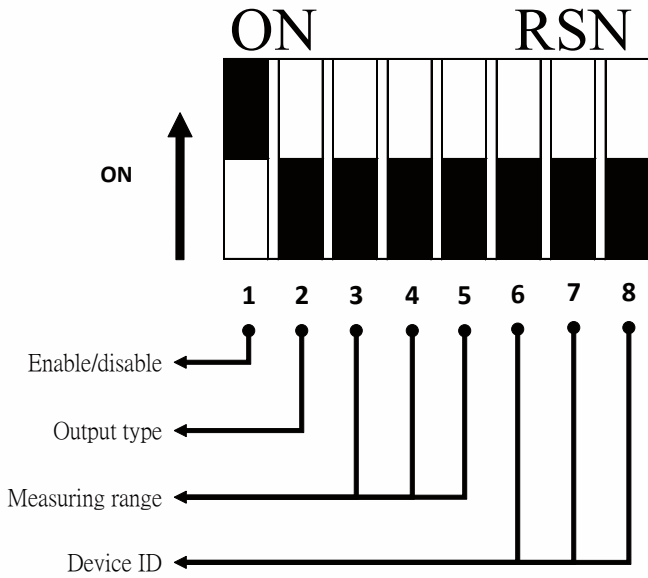

For FTS34/35 products, the setting status of DIP switch will be read by software while power on, and this reading action will not happen later on. Thus in order to read the DIP switch status again by software, the user must to reboot again if re-setting the DIP switch.

The function of DIP Switch_2 ~ 8 only be effective while setting the DIP switch_1 as "On" .

- 1. DIP Switch Active / Deactivate :
Set the DIP switch as On/ Off

STATUS	ON	OFF
DIP switch 1		

- 2. The Type for Analog Output: Analog output type for Out1 & Out2

STATUS	0-10V	4-20mA
DIP Switch 2		

- 3. Setting the Output Measuring Range :
Set the maximum value for analog output
(The output physical type must be "Air Flow Velocity")
※ Only switch wide to small range

DIP Switch 3	DIP Switch 4	DIP Switch 5	RANGE (m/s)
			1
			2
			5
			10
			15
			20
			40
			non

- 4. Setting the Device ID :

DIP Switch 6	DIP Switch 7	DIP Switch 8	Device ID
			1
			2
			3
			4
			5
			6
			7
			8