

Low Profile Compression Load Cell

>Model CL

Low Profile Compression Service Load Cell.
 Hopper, Tank Weighing
 CL : Painted finished steel, Protection Class IP67.
 CLH : Nikel planted steel

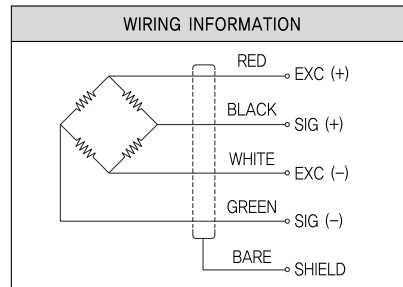
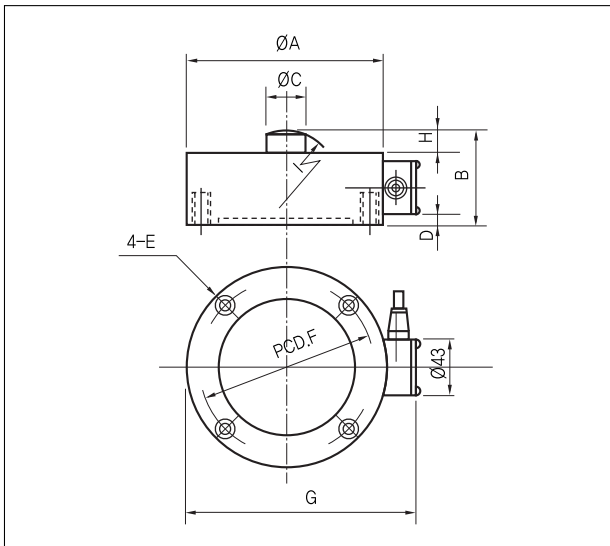

>SPECIFICATIONS

Specifications	Accuracy	
	CL	CLH
Rated capacity(R.C.)	500kgf, 1tf, 2tf, 5tf, 10tf, 20tf, 50tf, 100tf, 200tf, 300tf, 500tf	500kgf, 1tf, 2tf, 5tf, 10tf, 20tf, 50tf
Rated output(R.O.)	2mV/V±0.1%	2mV/V±0.1%
Nonlinearity	0.05% of R.O.(100tf, 200tf : 0.1%)	0.02% of R.O.
Hysteresis	0.05% of R.O.(100tf, 200tf : 0.1%)	0.02% of R.O.
Repeatability	0.03% of R.O.(100tf, 200tf : 0.05%)	0.02% of R.O.
Zero balance	±2% of R.O.	±2% of R.O.
Temperature effect on rated output	0.05% of LOAD/10°C	0.03% of LOAD/10°C
Temperature effect on zero balance	0.05% of R.O./10°C	0.03% of R.O./10°C
Temperature range, compensated	-10~60°C	-10~60°C
Temperature range, safe	-20~80°C	-20~80°C
Terminal resistance, input	700±30Ω	700±30Ω
Terminal resistance, output	700±3Ω	700±3Ω
Insulation resistance bridge/case	2000MΩ	2000MΩ
Excitation recommended	10V	10V
Safe overload	150% R.C.	150% R.C.
Cable length	Ø7mm 4core, 3m	Ø7mm 4core, 3m

>DIMENSIONS TABLE

unit:mm

Capacity	ØA	B	ØC	D	E	ØF	G	H	RI	Weight(kg)
500kgf (4.903kN)	88	30	16	1.5	M6×1 DP10	70	119	5	60	1.8
1tf (9.807kN)	98	46	22	1.5	M8×1.25 DP12	80	129	7	60	2.6
2tf (19.61kN)	98	46	22	1.5	M8×1.25 DP12	80	129	7	60	
5tf (49.03kN)	98	46	22	1.5	M8×1.25 DP12	80	129	7	60	3.8
10tf (98.07kN)	118	65	24	11	M8×1.25 DP12	98	149	7	80	
20tf (196.1kN)	157	65	34	11	M8×1.25 DP12	120	188	10	100	8
30tf (294.2kN)	187	75	50	16	M12×1.75 DP20	150	218	10	140	14
50tf (490.3kN)	187	75	50	16	M12×1.75 DP20	150	218	10	140	14
100tf (980.7kN)	278	120	74	37	M12×1.75 DP20	240	309	15	160	45
200tf (1.961MN)	320	170	100	63.5	M16×2 DP20	270	351	15	250	85
300tf (2.942MN)	396	195	140	68.5	M16×2 DP20	330	427	15	320	180
500tf (4.903MN)	430	200	150	68.5	M20×2.5 DP25	360	485	20	320	220

★Specifications are subject to change without notice.