



Pressure level transmitter



Level sensing relative and absolute pressure transmitter

Type 713

The pressure level transmitter type 713 is used for continuous fluid level measurement of ground and drinking water. The compact design allows the transmitter to be used in applications with restricted access as small as $\frac{3}{4}$ inch i.d. pipe.

As well as a current output the pressure level transmitter type 713 has been enhanced with energy efficient ratiometric and digital outputs making it ideal for battery powered applications.

The pressure level sensor 713 is based upon the well proven ceramic technology developed by Huba Control over 20 years ago.

Pressure range
0 ... 0.6 - 16 bar

- + Ceramic sensor Al_2O_3 99.6%
- + Continuous level measurement
- + Suitable for drinking water
- + Available with integrated temperature measurement
- + Applicable in $\frac{3}{4}$ inch pipes
- + Excellent linearity and long term stability

Technical overview

Pressure range

Relative	0 ... 0.6 - 16 bar
Absolute	0.8 ... 1.4 - 3 bar

Operating conditions

Medium	Groundwater Drinking water (with EPDM O-ring)
Temperature	Medium and ambient ¹⁾ Storage -20 ... +80 °C -40 ... +80 °C
Overload	acc. order code selection table

Materials in contact with medium

Case	Stainless steel 1.4404 / AISI 316L
Sensor	Ceramic Al ₂ O ₃ (99.6%)
Cable	PE-HD
Protection cover	PPE
Sealing material	FPM, EPDM (for drinking water)

Electrical overview

	Outout	Power supply	Load	Current consumption
Analogue	2 wire 4 ... 20 mA	10 ... 30 VDC	< $\frac{\text{power supply} - 10 \text{ V}}{0.02 \text{ A}}$ [Ohm]	< 23 mA
	3 wire ratiom. 10 ... 90%	5 VDC ±10%	> 10 kOhm / < 100 nF	< 3 mA
	4 wire ratiom. 10 ... 90%	5 VDC ±10%	> 10 kOhm / < 100 nF	< 3 mA
	(with temperature) Pressure Temperature acc. page 5	5 VDC ±10%	> 1 MOhm / < 100 nF	< 3 mA
Digital ²⁾ (one wire interface)	3 wire 3000 ... 11000 Digits (with temperature) Pressure Temperature acc. page 5	5 VDC ±10%	5 VDC ±10%	< 3 mA
Polarity reversal protection	Short circuit proof and protected against polarity reversal.		5 VDC ±10%	< 3 mA
Overvoltage protection		4 ... 20 mA / 0 ... 10 V ratiom. 10 ... 90 %	36 VDC 6 VDC	
Electric strength towards case			500 VDC	

Dynamic response

Response time	< 2 ms
---------------	--------

Runtime

Time starts at the moment of application of minimal supply voltage	< 10 ms
--------------------------------------------------------------------	---------

Electrical connection

Cable PE-HD 2 ... 175 m ³⁾	Protection standard IP 68	Protection class III
---------------------------------------	------------------------------	-------------------------

Test / Admissions

Electromagnetic compatibility	CE-conform acc. to EN 61326-2-3
Drinking water verification certificate for plastic parts	UBA guidance (KtW and elastomer) DVGW process sheet W270
Drinking water approval	ACS WRAS
EAC	
UL	ANSI/UL 61010-1 acc. E325110
Shock acc. IEC 60068-2-27	25 g, 6 ms, half sine wave, all 3 directions
Vibration nach IEC 60068-2-6	1 g, 2 ... 2000 Hz with amplitude ±15 mm, 1 Octave/min. all 3 directions

Weight

Without cable	~ 120 g
---------------	---------

Packaging

Single packaging
Multiple packaging

Accuracy

Standard

Parameter	Unit	
Max. deviation at 25 °C ⁴⁾	% fs	± 0.6
Resolution	% fs	0.1
Thermal characteristic ⁵⁾	% fs/10K	± 0.1
Long term stability acc. IEC EN 60770-1	max. % fs	± 0.25

Higher accuracy

Parameter	Unit	
Max. deviation ^{4), 5)}	% fs	± 0.4
Resolution	% fs	0.1
Long term stability acc. IEC EN 60770-1	max. % fs	± 0.25

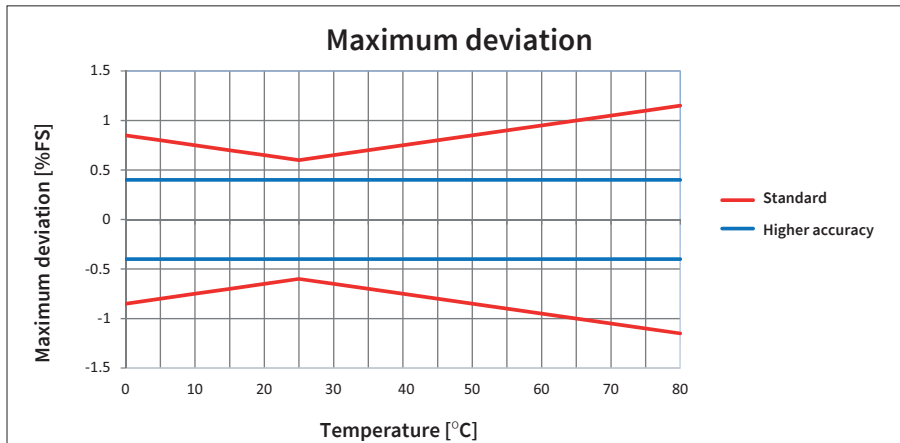

¹⁾ non-congealing media

²⁾ Application note one wire digital out

³⁾ for digital output max. 60 m

⁴⁾ incl. zero point, full scale, linearity, hysteresis and repeatability ⁵⁾ at 0 ... +80 °C

			1	2	3	4	5	6	7	8	9	10	11			
Order code selection table			713. X X X X X X X X X X X X													
Pressure mode	Absolute		8													
	Relative		9													
	Absolute with higher accuracy		C													
	Relative with higher accuracy		D													
Pressure range ¹⁾ (relative in bar)	overload															
	0 ... 0.6 bar	4.8 bar	9,D	1	0											
	0 ... 1.0 bar	4.8 bar	9,D	1	1											
	0 ... 1.6 bar	4.8 bar	9,D	1	2											
	0 ... 2.5 bar	7.5 bar	9,D	1	4											
	0 ... 4.0 bar	12.0 bar	9,D	1	5											
	0 ... 6.0 bar	18.0 bar	9,D	1	7											
	0 ... 10.0 bar	20.0 bar	9,D	3	0											
	0 ... 16.0 bar	20.0 bar	9,D	3	1											
Pressure range ¹⁾ (absolute)	0.8 ... 1.4 bar	4.8 bar	8,C	1	1											
	0.8 ... 2.0 bar	6.0 bar	8,C	1	2											
	0.8 ... 3.0 bar	9.0 bar	8,C	1	4											
Sealing material	FPM Fluoro-elastomer							0								
	EPDM Ethylene propylene (for drinking water)							1								
Outout / power supply	4 ... 20 mA	10 ... 30 VDC	2 wire (with housing connection)					0								
	ration. 10 ... 90%	5 VDC ±10%	3 wire					1								
	ration. 10 ... 90%	5 VDC ±10%	4 wire (with temperature)					2								
	3000 ... 11000 Digits	5 VDC ±10%	3 wire (one wire interface, with temperature)					3								
Electrical connection ²⁾	Cable	2 m							0	0	1	1				
		3 m							0	1	1	1				
		5 m								0	2	1	1			
		7 m								0	3	1	1			
		10 m								0	4	1	1			
		15 m								0	5	1	1			
		20 m								0	6	1	1			
		25 m								0	7	1	1			
		30 m								0	8	1	1			
		40 m								0	9	1	1			
		50 m								1	0	1	1			
		60 m								1	1	1	1			
		70 m								0,12	1	2	1	1		
		80 m								0,12	1	3	1	1		
		90 m								0,12	1	4	1	1		
		100 m								0,12	1	5	1	1		
125 m								0,12	1	6	1	1				
150 m								0,12	1	7	1	1				
175 m								0,12	1	8	1	1				
Admissions	without drinking water approval													0		
	with drinking water approval								1				1	1		
Pressure range variation (optional)	Indicate W and state range on order (e.g.: W0... +2bar/OUT4...20mA)													W		

Dimensions in mm / Electrical connections

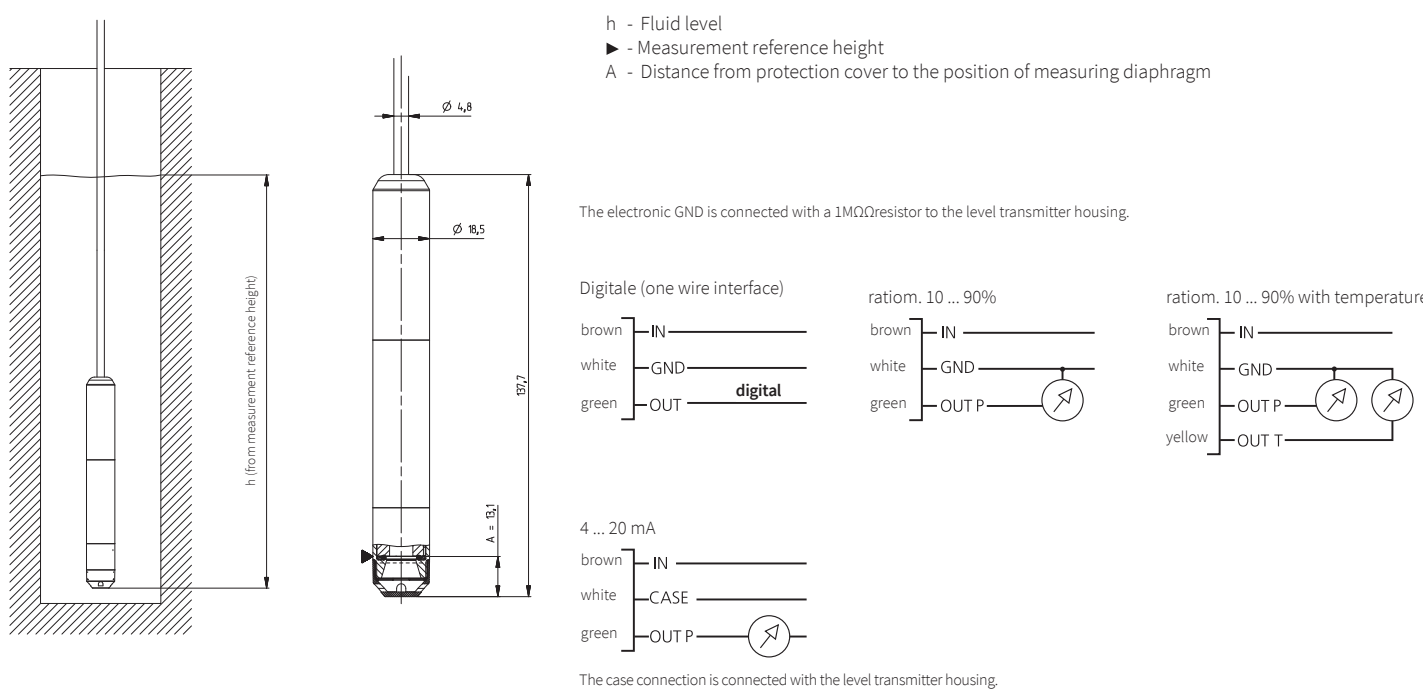

¹⁾ Other pressure range on request ²⁾ Other cable length on request

Cable hanger	118026
Connection box	118027
Humidity protection element (pack of 10)	118068
Calibration certificate	104551

Connection box

Cable hanger

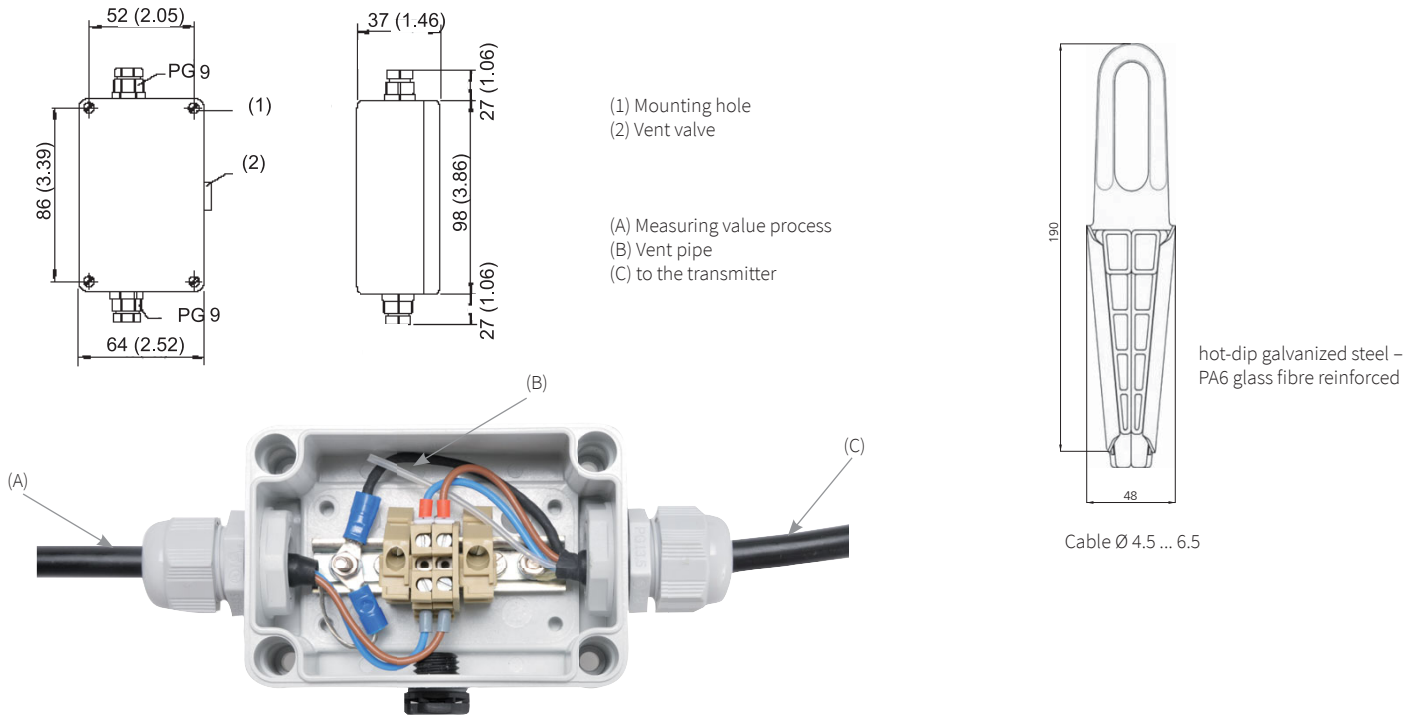

Calculation of level

General level with relative pressure sensor:

$$h = \frac{\Delta p}{\rho \cdot g}$$

General level with absolute pressure sensor:

$$h = \frac{P_{TS} - P_{Baro}}{\rho \cdot g}$$

which

$$P_{TS} = \frac{U_{TS} - U_{TS_NP}}{U_{TS_EW} - U_{TS_NP}} \cdot (P_{TS_EW} - P_{TS_NP}) + P_{TS_NP}$$

and

$$P_{Baro} = \frac{U_{Baro} - U_{Baro_NP}}{U_{Baro_EW} - U_{Baro_NP}} \cdot (P_{Baro_EW} - P_{Baro_NP}) + P_{Baro_NP}$$

Using a second level sensor as barometric air pressure sensor

For level sensor with current output use nominal signal values for I_{TS} ... instead of variables U_{TS} ... (resp. I_{Baro} ... instead of U_{Baro} ...)

Simplification of formula for level sensor with ratiometric output:

$$P_{TS} = \frac{U_{TS} - 0.1 \cdot U_{IN}}{0.8 \cdot U_{IN}} \cdot (P_{TS_EW} - P_{TS_NP}) + P_{TS_NP}$$

$$P_{Baro} = \frac{U_{Baro} - 0.1 \cdot U_{IN}}{0.8 \cdot U_{IN}} \cdot (P_{Baro_EW} - P_{Baro_NP}) + P_{Baro_NP}$$

Using a second level sensor as barometric air pressure sensor

Legend:

h	level [m]	ρ	density of media [kg/m ³]
		g	acceleration of fall 9.80665 [m/s ²]
Δp	measured relative pressure [Pa]	U_{TS}	signal on level sensor output [V or mA]
P_{TS}	measured pressure of level sensor [Pa]	U_{BARO}	Signal on barometer output [V or mA]
P_{BARO}	measured pressure of barometer [Pa]	U_{TS_NP}	minimal nominal signal of level sensor [V or mA]
P_{TS_NP}	minimal nominal pressure of level sensor [Pa]	U_{TS_EW}	maximum nominal signal of level sensor [V or mA]
P_{TS_EW}	maximum nominal pressure of level sensor [Pa]	U_{BARO_NP}	minimal nominal signal of barometer [V or mA]
P_{BARO_NP}	minimal nominal pressure of barometer [Pa]	U_{BARO_EW}	maximum nominal signal of barometer [V or mA]
P_{BARO_EW}	maximum nominal pressure of barometer [Pa]		

ration. 10 ... 90%

Digital

$$T_{TEMP} = T_0 + 1 / \left(a + b \cdot \ln \left(R \cdot \left[\frac{U_{IN}}{OUT T} - 1 \right] \right) + c \cdot \ln \left(R \cdot \left[\frac{U_{IN}}{OUT T} - 1 \right] \right)^3 \right)$$

$$T_{TEMP} = \left(\frac{T_{Dig}}{255} \cdot 200^\circ\text{C} \right) - 50^\circ\text{C}$$

T_{TEMP}	Sensor temperature [°C]	OUT T	sensor signal [V]
T_0	-273.15 [°C]	R	20'000 [Ω]
a	0.001204001	U_{IN}	power supply 5V ±10%
b	0.000208775		
c	0.000000294		

T_{TEMP}	Sensor temperature [°C]
T_{Dig}	digital value (0 ... 255 digits)
Max. error ±3 °C (bei 0 ... 80 °C)	

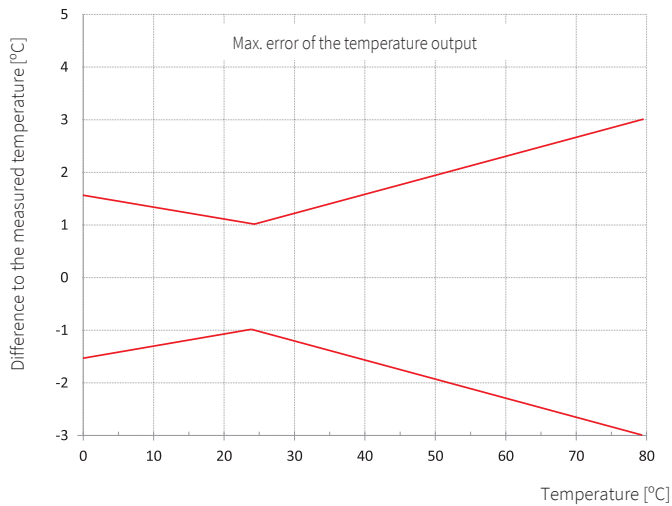
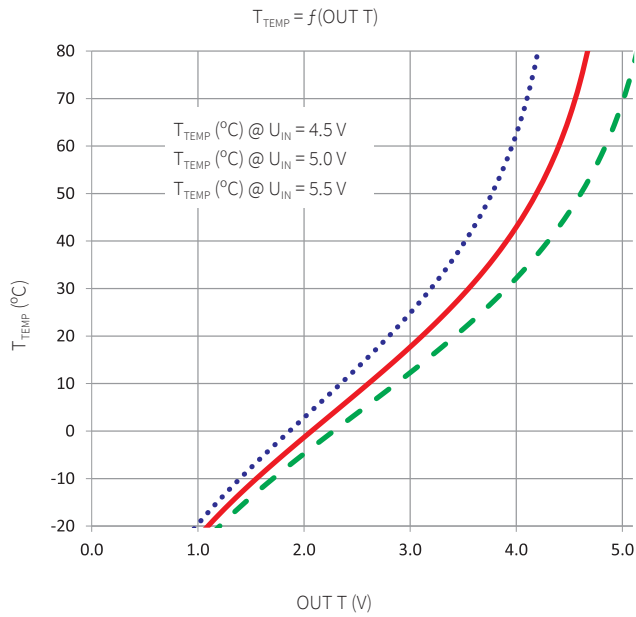

Huba Control AG

Headquarters Schweiz
Industriestrasse 17
CH-5436 Würenlos
Telefon +41 56 436 82 00
Fax +41 56 436 82 82
info.ch@hubacontrol.com

Huba Control AG

Niederlassung Deutschland
Schlattgrabenstrasse 24
D-72141 Walddorfhäslach
Telefon +49 7127 2393 00
Fax +49 7127 2393 20
info.de@hubacontrol.com

Huba Control AG

Vestiging Nederland
Hamseweg 20A
NL-3828 AD-Hoogland
Telefoon +31 33 433 03 66
Telefax +31 33 433 03 77
info.nl@hubacontrol.com

Huba Control SA

Succursale France
Rue Lavoisier
Technopôle Forbach-Sud
F-57602 Forbach Cedex
Téléphone +33 3 87 84 73 00
Télécopieur +33 3 87 84 73 01
info.fr@hubacontrol.com

Huba Control AG

Branch Office United Kingdom
Unit 13 Berkshire House, County Park
Business Centre, Shivenham Road
Swindon - Wiltshire SN1 2NR
Phone +44 1993 77 66 67
Fax +44 1993 77 66 71
info.uk@hubacontrol.com

www.hubacontrol.com

