



Pressure transmitter

Relative pressure transmitter for mobile hydraulic Type 512

The pressure transmitter type 512 with cable connection meets the highest demands of industrial and mobile hydraulic applications. This sensor is available with protection standard IP 69K. The standard pressure orifice prevents damage due to pressure peaks.

The compact and rugged design meets the requirement of shock- and vibration stability according to Kfz-norm ISO 16750. The pressure transmitter type 512 guarantees highest EMC stability according to various Kfz regulations with test level up to 100V/m.

The measuring cell is based upon the Huba Control developed thick film technology on stainless steel and is fully hermetically welded.

- + Compact and rugged construction for highest operational reliability
- + Welded construction – no elastomer seals
- + Negligible temperature influence on accuracy
- + Excellent EMC-capacity
- + Rugged PUR cable with IP 69K

Pressure range
0 ... 40 – 1000 bar



Technical Overview

Pressure range

Relative 0 ... 40 – 1000 bar

Operating conditions

Medium		Liquids and gases
Temperature	Medium	-40 ... +125 °C
	Ambient	-40 ... +100 °C
	Storage	-40 ... +100 °C
Tolerable overload	≤ 400 bar	3 x FS
	> 400 bar	2.5 x FS (max. 1500 bar)
Rupture pressure	≤ 400 bar	6 x FS
	> 400 bar	4 x FS (max. 2500 bar)

Materials

Case		Stainless steel 1.4404 / AISI 316 L
Cable		PUR
Materials in contact with the medium	Pressure connection	Stainless steel 1.4404 / AISI 316 L
	Sensor	Stainless steel

Electrical overview

	Output	Power supply	Load	Current consumption
2 wire	4 ... 20 mA	9.5 ... 33 VDC	$< \frac{\text{Power supply} - 9.5V}{0.02A}$ [Ohm]	< 23 mA
	0 ... 5 V	7.5 ... 33 VDC	>10 kOhm / < 100 nF	< 7 mA
3 wire	1 ... 6 V	8.5 ... 33 VDC	>10 kOhm / < 100 nF	< 7 mA
	0 ... 10 V	12.5 ... 33 VDC	>10 kOhm / < 100 nF	< 7 mA
	ration. 10 ... 90%	5 VDC ± 10%	>10 kOhm / < 100 nF	< 7 mA
Insulation voltage				1000 VDC
Polarity reversal protection	Short circuit proof and protected against polarity reversal. Each connection is protected against crossover up to max. supply voltage.			

Dynamic response

Response time	< 2 ms (10... 90%, typ. 1 ms)
Load cycle	< 100 Hz

Electrical connection

Cable PUR 1.5 m

Protection standard

IP 69K, IP 68

Protection class

III

Pressure connection

Outside thread	$\frac{7}{16}$ - 20 UNF	sealed at back SAE-4 with O-Ring seal FPM (-20 ... +135 °C)
	$\frac{1}{4}$ - 18 NPT	
	G $\frac{1}{4}$	sealed at back DIN 3852-E with profile seal FPM (-30 ... +135 °C)
	M14x1.5	sealed at back DIN 3852-E with profile seal FPM (-30 ... +135 °C)
	$\frac{9}{16}$ - 18 UNF	sealed at back SAE-6 with O-Ring seal FPM (-20 ... +135 °C)
	R $\frac{1}{4}$	EN 10226

Installation arrangement

Unrestricted

Tests / Admissions

Electromagnetic compatibility	Noise immunity / Noise emission	Noise immunity automotive guideline	Noise emission automotive guideline
	ISO 13766 - earth-moving equipment	ISO 11452-2, HF (Field), 100 V/m (200 ... 2000 MHz)	CISPR11
	DIN EN 13309 - construction equipment	ISO 11452-4, HF (BCI), 100 mA (20 ... 400 MHz)	
	DIN ISO 14982 - agriculture and forestry	ISO 10605, ESD, ±15 kV contact, ±15 kV air	
	Automotive guideline ECE R10 ¹⁾	ISO 7637-2, puls, test level 4 ^{2),3)}	
	Automotive guideline 2004/104/EG ¹⁾	ISO 16750-2, Load Dump, 155 V (1Ω, 300 ms)	
	EN 61326-2-3 - pressure transducer		
Noise immunity (industry)	EN 12895:2015 - industrial trucks		
Noise emission (residential and commercial area)	EN 61000-6-2		
Environmental test	EN 61000-6-3		
Shock acc. IEC 68-2-27	ISO 16750-Z-J-A-L-Z IP69K		
Vibration acc. ISO 16750-3	50 g, 11 ms, half sine wave, 1000x / axis		
cULus	Test VI (12 g, sinusoidal 18 g random vibration)		
	ANSI/UL 61010-1 acc. E325110		

Weight

~ 176 g

Packaging (Please state on order)

Single packaging in cardboard
Multiple packaging in cardboard (2 pcs)
Multiple packaging in cardboard (25 pcs)

Accuracy

Parameter	Unit	
Characteristic line acc. IEC 61298-2 ⁴⁾	% fs	± 0.5
Resolution	% fs	0.1
Thermal characteristic ⁵⁾	max. % fs/10K	± 0.2
Long term stability acc. IEC 61298-2	max. % fs	± 0.3

Test conditions: 25 °C, 45% RH

¹⁾ E1 approval for customer specific type on request

²⁾ Puls 1, 2a, 2b, 3a, 3b

³⁾ Pressure sensor for 12 V and 24 V power system (0 ... 5 V, 0 ... 10 V / 1 ... 6 V and 4 ... 20 mA)

⁴⁾ incl. zero point, full scale, linearity, hysteresis and repeatability

⁵⁾ -40 ... 100 °C

		1	2	3	4	5	6	7	8	9	10	11	
Order code selection table in bar		512.	X	X	X	X	X	X	X	X	X	X	
Pressure range ¹⁾	0 ... + 40 bar	9	3	3	S	0							
	0 ... + 60 bar	9	4	0	S	0							
	0 ... + 100 bar	9	4	1	S	0							
	0 ... + 160 bar	9	4	2	S	0							
	0 ... + 250 bar	9	4	3	S	0							
	0 ... + 400 bar	9	5	4	S	0							
	0 ... + 600 bar	9	5	5	S	0							
	0 ... + 1000 bar	9	5	7	S	0							
Output / power supply	0 ... 5 V								1				
	0 ... 10 V								2				
	1 ... 6 V								6				
	4 ... 20 mA								3				
	10 ... 90% ratiom.								7				
Electrical connection	Cable 1.5 m								L				
Pressure connection ¹⁾	Outside thread	⁷ / ₁₆ -20 UNF sealed at back SAE-4 with O-Ring seal FPM								G	2	1	
		¹ / ₄ -18 NPT								3	2	1	
		G ¹ / ₄ sealed at back DIN 3852-E with profile seal FPM									4	2	1
		M14x1.5 sealed at back DIN 3852-E with profile seal FPM									6	2	1
		R ¹ / ₄ acc. EN 10226									7	2	1
⁹ / ₁₆ -18 UNF sealed at back SAE-6 with O-Ring seal FPM									V	2	1		
Pressure range variation (optional)	Indicate W and state range on order (e.g. W0... + 300bar/Out1...8V)											W	

		1	2	3	4	5	6	7	8	9	10	11	
Order code selection table in psi		512.	X	X	X	X	X	X	X	X	X	X	
Pressure range ¹⁾	0 ... + 600 psi	9	C	4	S	0							
	0 ... + 750 psi	9	D	0	S	0							
	0 ... + 1000 psi	9	D	1	S	0							
	0 ... + 2000 psi	9	D	2	S	0							
	0 ... + 3000 psi	9	D	3	S	0							
	0 ... + 5000 psi	9	E	4	S	0							
	0 ... + 7500 psi	9	E	5	S	0							
	0 ... + 14500 psi	9	E	7	S	0							
Output / power supply	0 ... 5 V								1				
	0 ... 10 V								2				
	1 ... 6 V								6				
	4 ... 20 mA								3				
	10 ... 90% ratiom.								7				
Electrical connection	Cable 1.5 m								L				
Pressure connection ¹⁾	Outside thread	⁷ / ₁₆ -20 UNF sealed at back SAE-4 with O-Ring seal FPM								G	2	1	
		¹ / ₄ -18 NPT								3	2	1	
		G ¹ / ₄ sealed at back DIN 3852-E with profile seal FPM									4	2	1
		M14x1.5 sealed at back DIN 3852-E with profile seal FPM									6	2	1
		R ¹ / ₄ acc. EN 10226									7	2	1
⁹ / ₁₆ -18 UNF sealed at back SAE-6 with O-Ring seal FPM									V	2	1		
Pressure range variation (optional)	Indicate W and state range on order (e.g. W0... + 4000psi/Out1...8V)											W	

		1	2	3	4	5	6	7	8	9	10	11	
Order code selection table in MPa		512.	X	X	X	X	X	X	X	X	X	X	
Pressure range ¹⁾	0 ... + 4 MPa	9	H	3	S	0							
	0 ... + 6 MPa	9	K	0	S	0							
	0 ... + 10 MPa	9	K	1	S	0							
	0 ... + 16 MPa	9	K	2	S	0							
	0 ... + 25 MPa	9	K	3	S	0							
	0 ... + 40 MPa	9	L	4	S	0							
	0 ... + 60 MPa	9	L	5	S	0							
	0 ... + 100 MPa	9	L	7	S	0							
Output / power supply	0 ... 5 V								1				
	0 ... 10 V								2				
	1 ... 6 V								6				
	4 ... 20 mA								3				
	10 ... 90% ratiom.								7				
Electrical connection	Cable 1.5 m								L				
Pressure connection ¹⁾	Outside thread	⁷ / ₁₆ -20 UNF sealed at back SAE-4 with O-Ring seal FPM								G	2	1	
		¹ / ₄ -18 NPT								3	2	1	
		G ¹ / ₄ sealed at back DIN 3852-E with profile seal FPM									4	2	1
		M14x1.5 sealed at back DIN 3852-E with profile seal FPM									6	2	1
		R ¹ / ₄ acc. EN 10226									7	2	1
⁹ / ₁₆ -18 UNF sealed at back SAE-6 with O-Ring seal FPM									V	2	1		
Pressure range variation (optional)	Indicate W and state range on order (e.g. W0... + 30MPa/Out1...8V)											W	

¹⁾ Other pressure range or pressure connection on request

Mounting bracket with screw	118716
Heat sink with outside thread G 1/2 sealed at front - inside thread G 1/4	105073
Heat sink with outside thread G 1/4 sealed at front - inside thread G 1/4	105074
Calibration certificate	104551

Mounting bracket

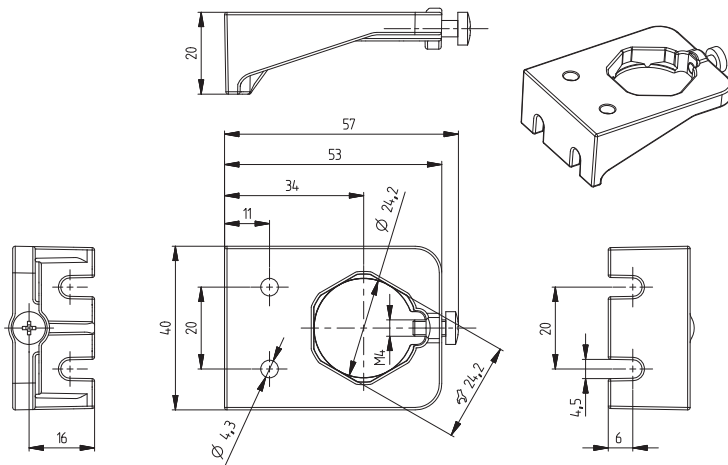

Heat sink

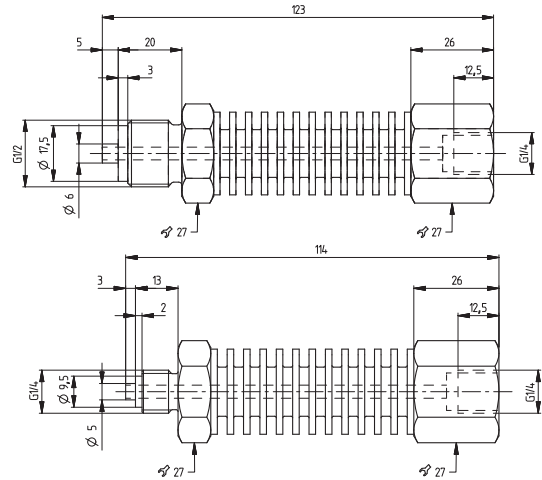

Dimensions in mm / Electrical connections

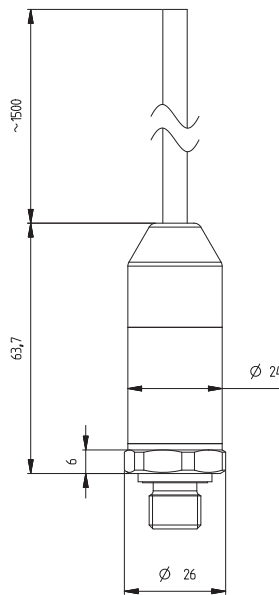
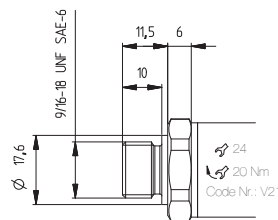
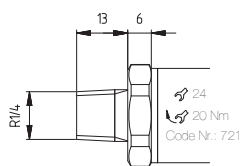
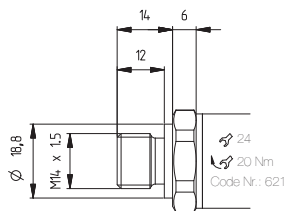
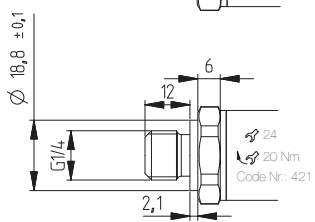
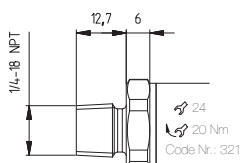
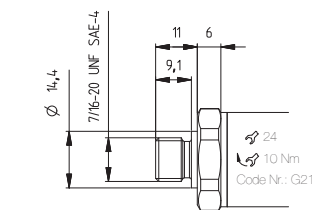

Attention: min. bending radius cable PUR ≥ 15x cladding-Ø

2 wire

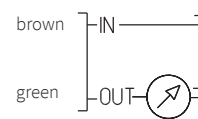

3 wire

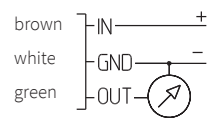

Huba Control AG

Headquarters Schweiz
Industriestrasse 17
CH-5436 Würenlos
Telefon +41 56 436 82 00
Fax +41 56 436 82 82
info.ch@hubacontrol.com

Huba Control AG

Niederlassung Deutschland
Schlattgrabenstrasse 24
D-72141 Walddorfhäslach
Telefon +49 7127 2393 00
Fax +49 7127 2393 20
info.de@hubacontrol.com

Huba Control AG

Vestiging Nederland
Hamseweg 20A
NL-3828 AD-Hoogland
Telefoon +31 33 433 03 66
Telefax +31 33 433 03 77
info.nl@hubacontrol.com

Huba Control SA

Succursale France
Rue Lavoisier
Technopôle Forbach-Sud
F-57602 Forbach Cedex
Téléphone +33 3 87 84 73 00
Télécopieur +33 3 87 84 73 01
info.fr@hubacontrol.com

Huba Control AG

Branch Office United Kingdom
Unit 13 Berkshire House, County Park
Business Centre, Shivenham Road
Swindon - Wiltshire SN1 2NR
Phone +44 1993 77 66 67
Fax +44 1993 77 66 71
info.uk@hubacontrol.com

www.hubacontrol.com

